

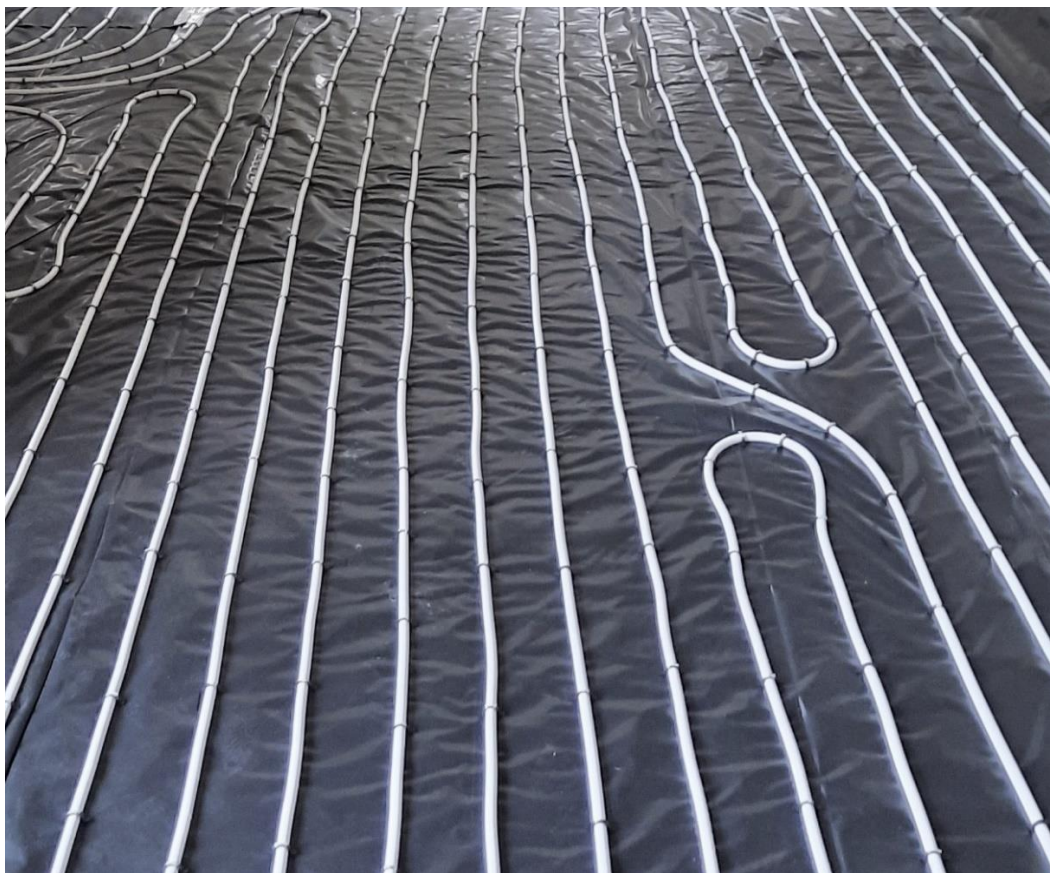

**Underfloor
Heating Systems Ltd**

**INSTALLATION INSTRUCTIONS
One Large Zone (multiple circuits)**



**Unit 1
79 Friar Street
Worcester
WR1 2NT**

Tel: 01905 354 791

**E-mail: info@underfloorheatingsystems.co.uk
Website: www.underfloorheatingsystems.co.uk**

1. Installation and preparation work

- Standard pipe spacing for concrete floor is 200 mm (boiler) or 150 mm where heat pumps are to be used. With timber suspended floors pipe spacing is set as 200 mm standard, assuming joists are set at 400 mm centres.
- Pipe to be kept 100 mm away from walls. Always go with flow to the cold spots first.
- **Maximum recommended individual loop length is 110 m** e.g. from a 200 metre coil use e.g. 110 + 90m.
- Fix the pipe to the insulation with the clips (6cm or 4cm) provided. On average you need approximate one to two clips per metre of pipe. We supply minimum two clips per metre.
- Aim to locate the manifold and centrally within the building.
- The room thermostat controls the underfloor heating pump. System layout and wiring diagram provided within this document however for most up to date wiring please follow Heatmiser thermostat manual. **The system needs to have independent control from the boiler, i.e. S-plan system with a two port valve** fitted on the 22 mm or 28 mm flow pipe.
- Try to use all the pipework supplied. You will usually have waste but where you have more pipe than required, simply reduce pipe spacing accordingly. **The pipe is marked every metre** so you'll know when it's time to return to the manifold.
- The loops on the pipe layout (if provided) are only rough estimations on total pipe lengths required per zone. As produced by software you'll find more practical ways on site.
- Pipe is normally NOT laid under kitchen and utility units or baths/shower trays.
- We recommend that you first install the manifold and the control pack, as per instructions provided. To fit the pipe to the manifold, cut the pipe end squarely using the pipe cutter. Re-round the pipe end with the calibration tool. Place the nut over the pipe, then the olive and finally push in the insert into the pipe and then attach to manifold port. The manifold is normally fitted within one metre above floor level.
- If you accidentally kink the pipe while bending it, the pipe should be straightened and re-arranged so that the location of the kink remains in a straight length.
- Mark up the room / zone that each pipe circuit applies. Also make a note of each circuit length (again the pipe is marked every metre).
- Prevent people from walking over the pipes until screeded over, keep tools etc. away from the pipes.
- Fill the system as instructions provided (see Chapter 2), using hosepipes. **Do not fill from the boiler filling loop.** If property isn't weathertight and freezing conditions are expected, you should instead use an air compressor and do an air test.
- It's important to purge the pipework from the boiler to the manifold, to avoid air being introduced into the underfloor heating system.

1. Installation and preparation work (continued)

We recommend a **minimum of 50 mm of PIR insulation**. This is very high quality insulation and can be used for both concrete and timber suspended floor constructions.

Fit 25 mm perimeter insulation along all outside walls as per building regulations. With liquid screeds you'll also need an expansion edging strip fitted along ALL vertical objects – plus a visqueen membrane above PIR insulation.

Note we do **NOT** supply PIR insulation. Any builder's merchant will have e.g. Xtratherm or Recticel insulation in stock. We recommend 65-75 mm of sand cement screed for concrete floors, for timber suspended floors see website or manual. Alternatively use minimum 50 mm fibre screed or liquid screed e.g. anhydrite.

As WC and bathrooms are very small areas, extra heat might be needed. Therefore it is standard practice to install towel rails in these areas, combined with the underfloor heating. Also reduce pipe spacing if necessary.

2. Floor finishes and maximum heat outputs

For stone and ceramics tiles it is recommended that two part flexible adhesives and de-coupling membranes are used.

Carpet and underlay should not exceed 2.5 Tog. Avoid underlays for carpet with felt and rubber crumb type. Never fit floor finishes on screed that isn't dry – switch the heating off 24 hours before fitting any floor finish.

With e.g. vinyl and karndean check with the flooring manufacturer if it's suitable with underfloor heating - and if any temperature restrictions apply. **With sensitive floor finishes it is recommended to install a floor sensor** (floor probe). Laminate flooring should have an expansion gap for movement.

Floorboards must have moisture content lower than 7 % before they are installed. We do not recommend floorboards or wooden floor inn general thicker than 25 mm, see website for further technical information. Always check with the manufacturer of any floor finish that it will work with underfloor heating and whether it may need a floor sensor.

If there are metal parts in the system it should be cleaned and flushed with Fernox or similar product. For a normal UK size property (Four Bedroom house) 22 mm flow and return to the manifold is suitable, for larger properties use 28 mm flow and return. We highly recommend that the plumber installs isolating valves before they connect the pipework to the manifold from the boiler, in case the pump needs servicing or the mixing valve needs cleaning out.

Underfloor heating can be 'mixed' with radiators. The underfloor heating system needs to be a **complete separate system**, i.e. the UFH flow and return needs to go all the way back to the boiler. If you do have radiators in your system, we recommend independent control from the boiler, i.e. not together with the underfloor heating. S-plan.

For combination boilers it is recommended to check with the manufacturer if the **boiler can be fitted with a secondary pump**. Sometimes if the project is just a small flat and the combi boiler is only providing UFH and hot water, it is possible to have the UFH system without the control unit. There need to be a safety device on the boiler to prevent the end user from adjusting the flow temperature above 60 degree C.

Maximum heat output for underfloor heating systems are 100 W/m² for concrete floors and 70 W/m² for timber suspended floors. For any underfloor heating system to work efficiently the property needs to be built to current building regulations. If you are using the underfloor heating for a Conservatory, it will extend the time you can use the Conservatory not keep it at 20 degree C all year as the heat losses are higher than 100 W/sqm in a Conservatory.

3. Manifold assembly

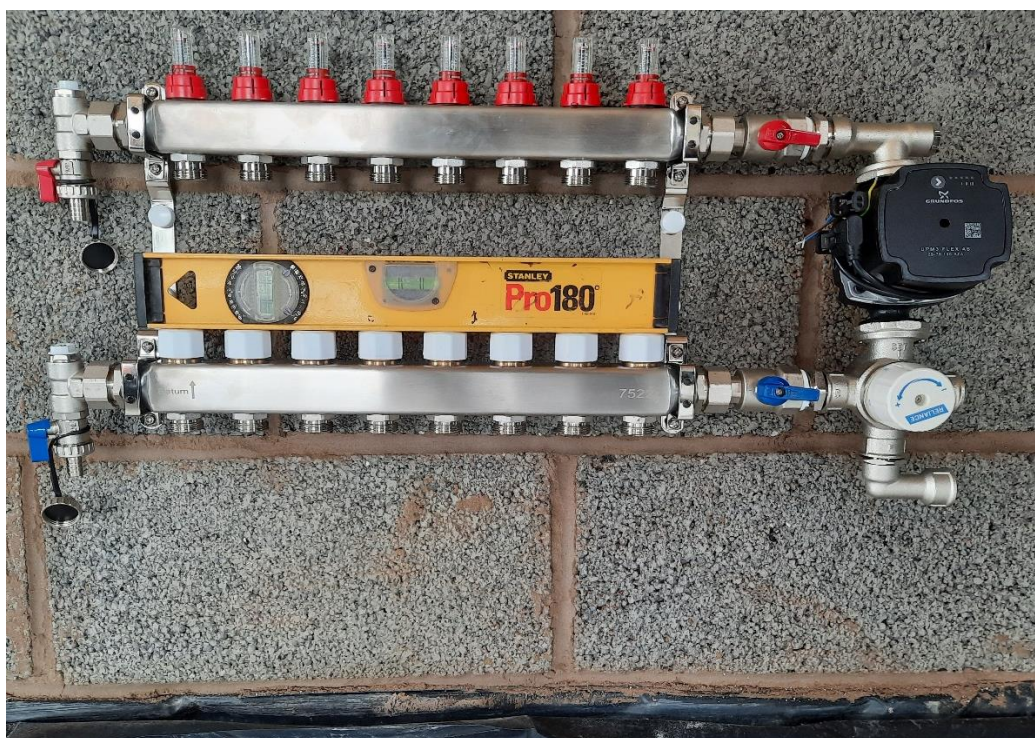

- 1) Attach the manifold to wall.
- 2) Fit ball valves & fill/drain valves to manifold (remember the washers!).
- 3) Tighten using water pump pliers.
- 4) See instruction that comes with the mixer pack.
- 5) Assemble pump & mixing valve as shown (remember washers!).
- 6) Connect supply pipework to mixing valve using $\frac{3}{4}$ " male iron compression fittings .

4. Filling the system with water

The system must be filled with water and fully vented of air. This can be best achieved using mains pressure through the two filling valves at the end of the manifolds. Both the isolation ball valves should be closed. The flow filling valve connected with a hose to the mains water supply, with the return filling valve connected to a hose laid to a wastewater point.

One by one each circuit is opened and closed, purging the loops of air.

Ensure that all the caps on the return manifold are closed. Open the isolators on the fill/drain valves. Open the first cap and wait until clear water is coming out. Make sure that all the air is gone. Close the cap and repeat the procedure with the next circuit. Continue the process – one by one - until all the circuits are filled and fully vented of all the air.

The system should be pressure tested with 5 bar for 24 hours before screeding.

When above is completed and the filling valves closed off, the pumps should be run for five minutes and the air vented again at the air bleed valve on the fill/drain valves until all air is bled from the system. **Do not fill the system from the boiler filling loop.**

The manifolds are supplied with options for individual control for each room. On the return manifold, actuators can be fitted for individual control. If a programmable room thermostat and a two port zone valve is controlling the system - and there is no individual control, leave all loops open (using the plastic caps). The flow manifolds are supplied with flow gauges. To adjust the flow gauges you can turn them clockwise (reducing flow) or anticlockwise (increasing flow).

The following is an approximate guide, as how far each loop should be adjusted;

<u>Size of Loop</u>	<u>Percentage Open</u>
10 – 30 metres	30 % open
40 – 60 metres	50 % open
60 – 90 metres	75 % open
90 – 110 metres	100 % open

If the return manifold is not getting warm, there is either air in the system or the flow and the return from the boiler is not correct fitted to the mixing valve. Run the pump on speed 3. The system should be on for 24 hours to confirm that all the loops are working.

Note, if there is a risk for the air temperature dropping below freezing, then you must protect the pipes and manifolds from freezing. It is always recommended to lay screed on top of the pipes as soon as they have been pressure tested.

5. Example of a one room pipe layout (with two pipe circuits)

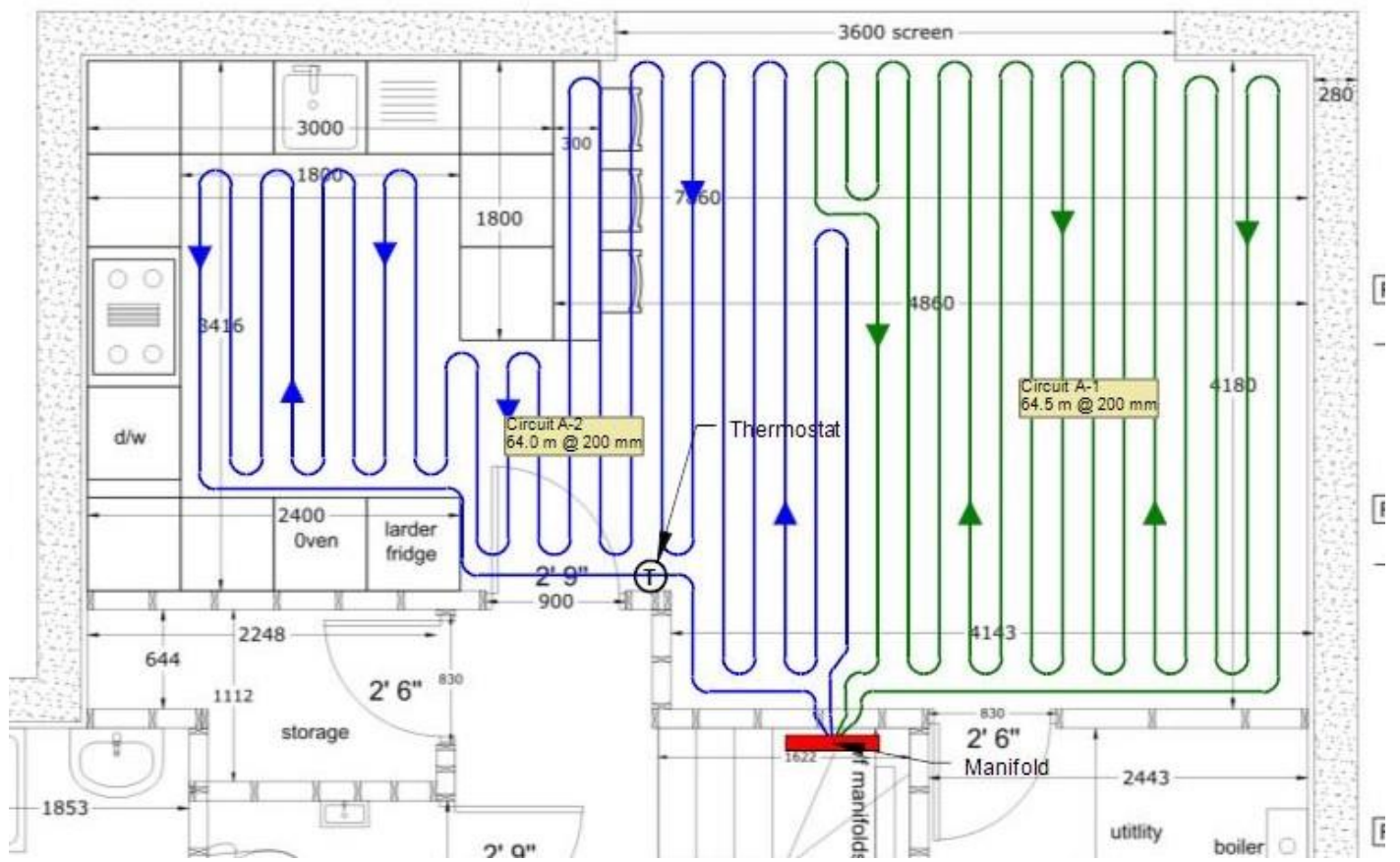

6. Commissioning

The screed must be allowed to dry for a **minimum of 4 to 6 weeks** before the heating is operated. As the system is used for the first time, the mixing valve must be set to minimum setting (25 degrees C) to let any remaining moisture in the screed gently dry out. The temperature should then be increased by one degree per day until the mixing valve is set at 45°C (or 35 C with sensitive floor finishes if recommended so by flooring manufacturers or fitters).

- 1) Screed or chipboard flooring should be laid immediately after pipe laying to protect the pipe.
- 2) Concrete screed floors must be cured before any heat is applied, a general rule of thumb is to allow 1 day per millimetre of screed for the first 40 mm, then allow 2 days per millimetre. It's recommended **you check the moisture content** before fitting any floor finish.
- 3) Timber suspended floors with drymix infill can have heat applied immediately, however the drymix must be dried completely before laying the flooring.
- 4) Hardwood timber flooring must be 'conditioned' before fixing.
- 5) The flow & return from the boiler should be connected to the manifold connections shown using compression couplings.
- 6) It's important to purge the pipework from the boiler to the manifold, to avoid air being introduced into the underfloor heating system.
- 7) Initially start the system with the thermostatic valve set at min (25° C).
- 8) Increase the setting by 1° degree C per day, up to a maximum of 45° C for concrete floors, max 60° for timber floors. Note – subject to floor finish!
- 9) Balance the loops as suggested in the instructions.

If the system for some reason makes a noise, then there is probably a bit of air in the system. The air can be removed from the end caps on the manifolds, similar to a radiator system.

7. Electrical controls

- 1) Thermostat position in the room is not critical but positions affected by the sun should be avoided, also not too near hobs / cooking area. Mounting height approx. 1.5 m.
- 2) The room thermostat is used to switch the pump, open 2 port motorized zone valve & boiler call. See wiring details provided.
- 3) Follow the Heatmiser thermostat user manual for the latest up to date wiring diagrams.
- 4) Run the underfloor heating once a month, for a short period of five minutes each time, even in the summer months. This will exercise the pump.

8. Electrical connections

TYPICAL ELECTRICAL CONNECTION SINGLE ZONE UFH + EXISTING S PLAN SYSTEM + SYSTEM BOILER

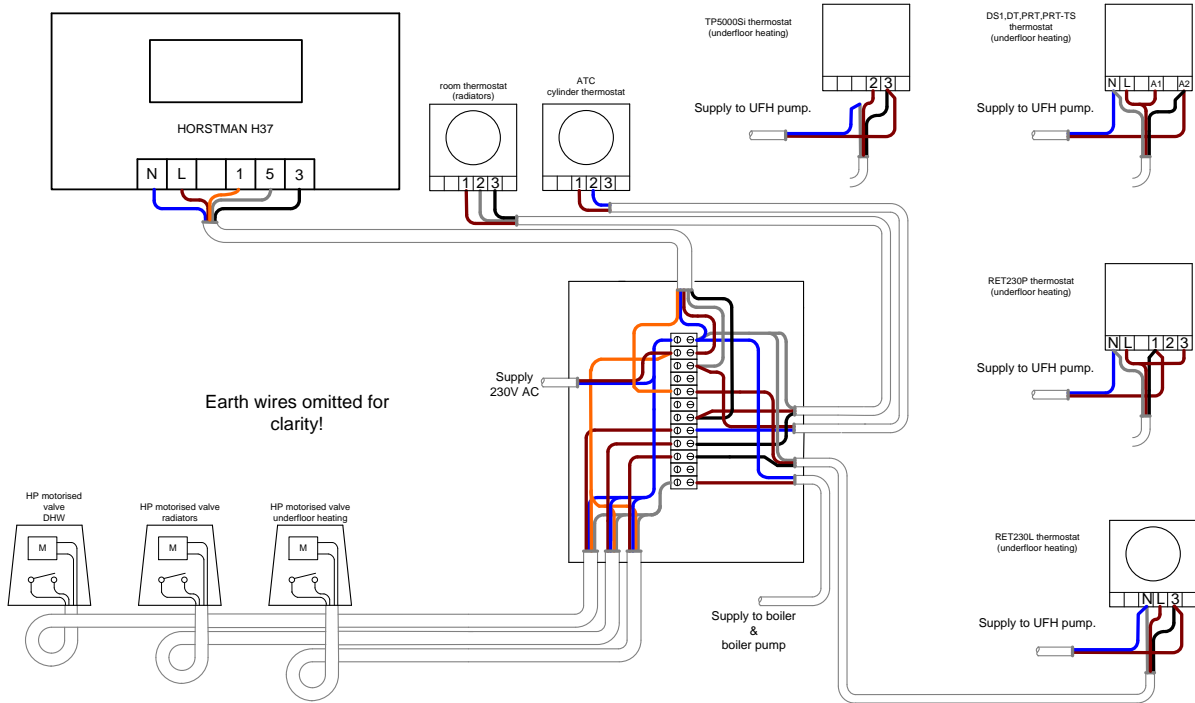

TYPICAL ELECTRICAL CONNECTION SINGLE ZONE UFH + RADIATORS + COMBINATION BOILER

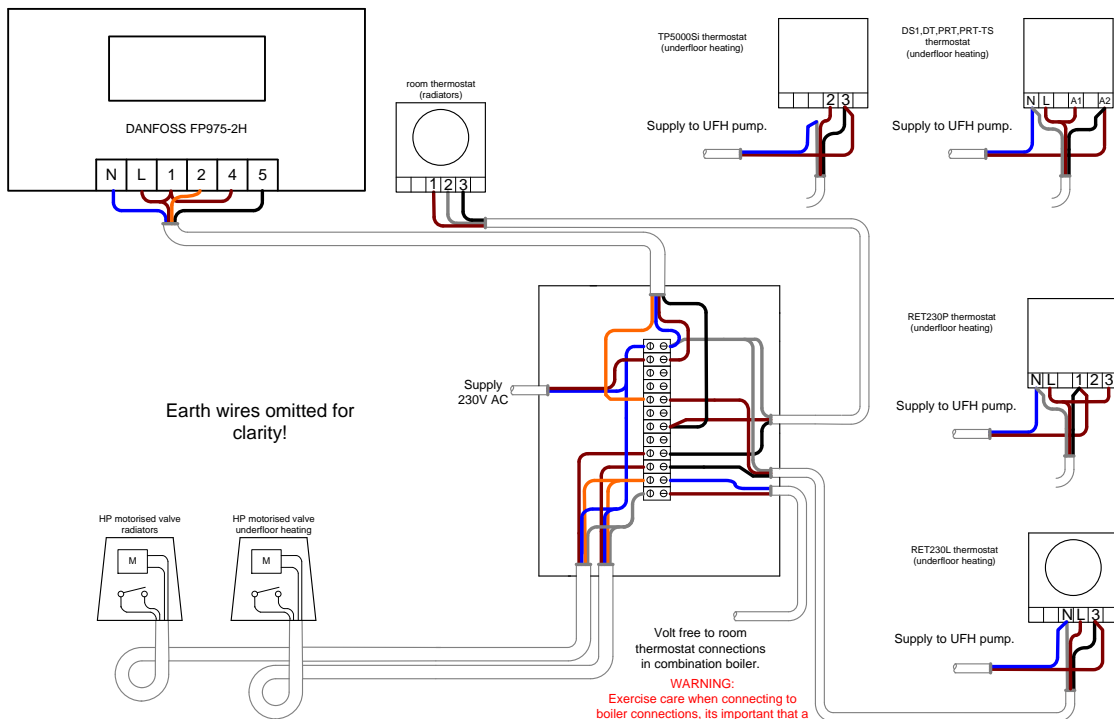

WARNING:
Exercise care when connecting to boiler connections, its important that a voltage is not applied to boiler terminals from this control system or damage to boiler may occur.

9. System schematics.

Schematic for system boiler
&
UFH + radiators + hot water

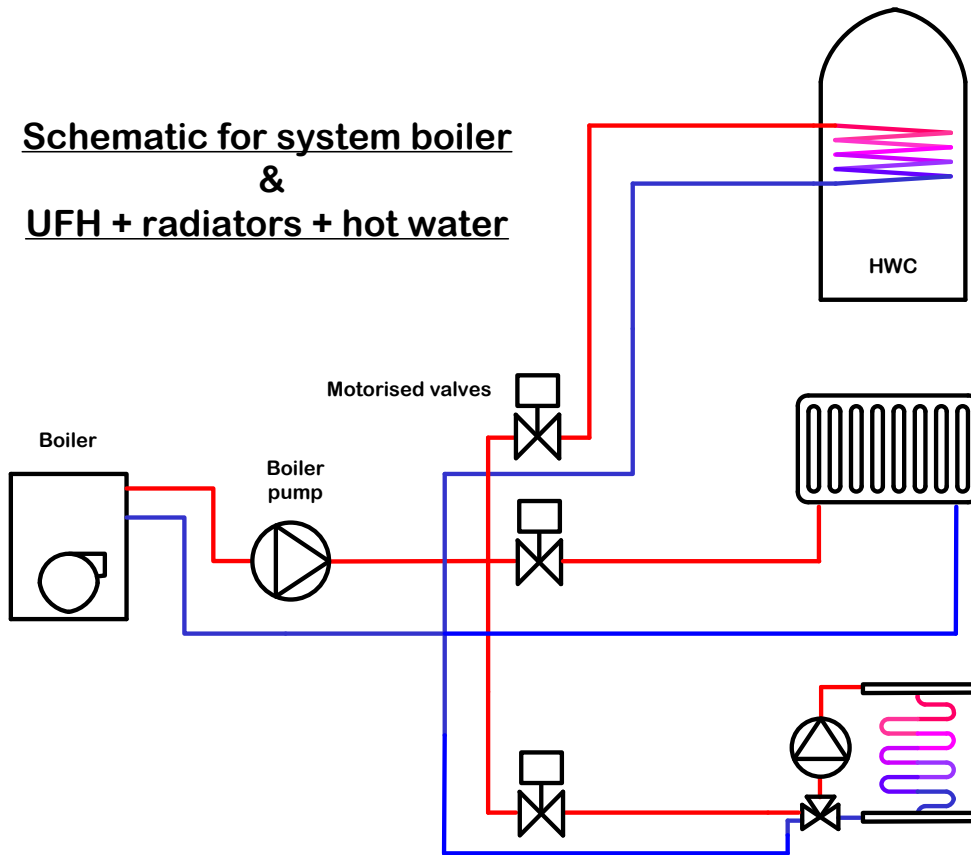

Schematic for gas combination boiler
&
underfloor heating + radiators

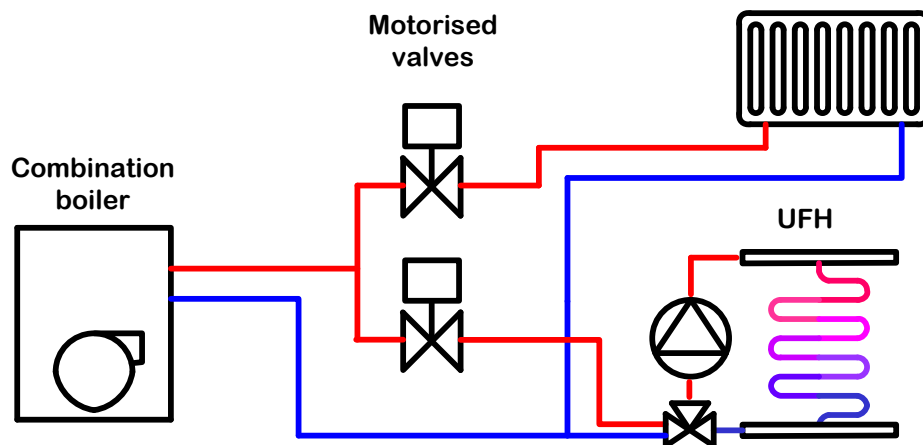

10. Floor types

Concrete Floor with staples (clips)

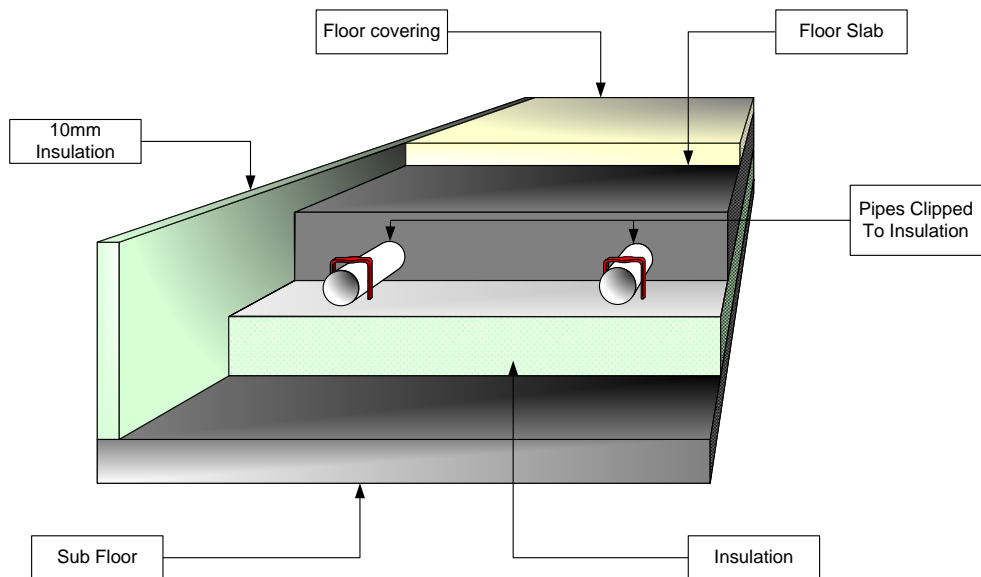

Timber Suspended Floor – pipe between joists

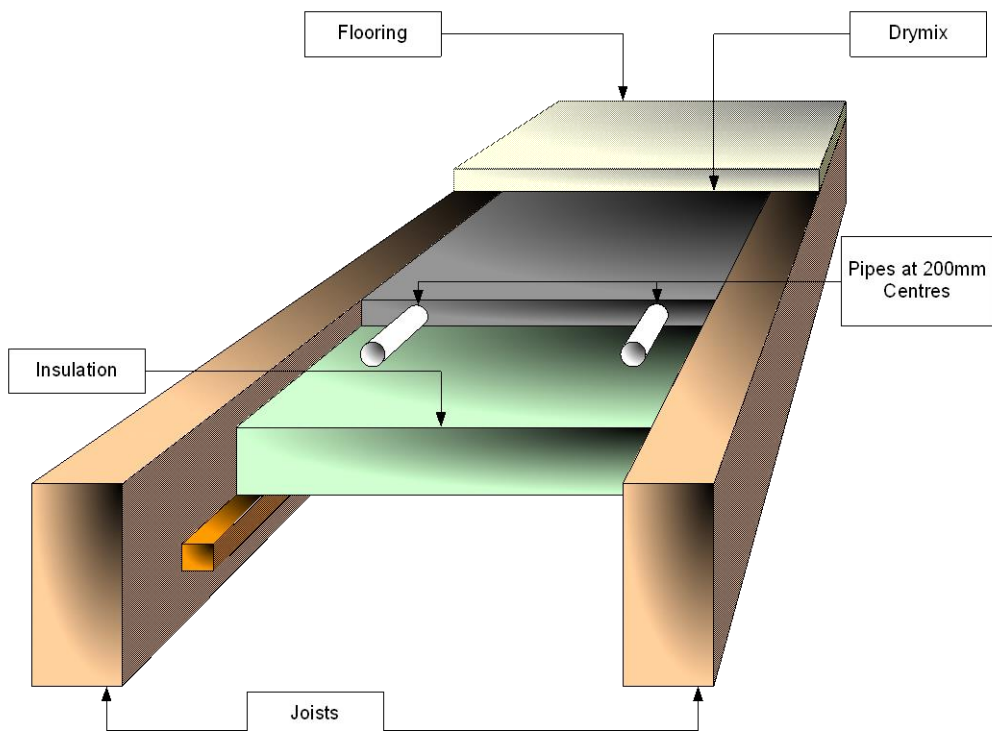

The Drymix is needed for Ground Floor, older buildings and if concrete floor and timber suspended floor are on the same floor. For First Floor applications when property is built to current building regulations an air gap is fine, still good to use the drymix as will give out more heat.

11. Additional notes

The underfloor heating system can be fitted in both concrete and timber suspended floors. See pictures above.

In **concrete screeded floors**, the floor screed acts to diffuse the heat across the surface providing an even temperature at the floor surface.

Normally a concrete slab is laid over DPM. 20 mm or 25 mm thick PIR insulation is fixed to the perimeter walls, to a height to include the depth of floor PIR insulation and screed.

Whilst the perimeter insulation may be on show it will be covered by wall plastering and skirting boards. For liquid screed projects we can supply expansion edging strip which will need to be fitted around ALL vertical objects.

PIR floor insulation is laid to the whole area, joints are taped to prevent the ingress of screed between the insulation boards. Make sure the surface below is flat and smooth so the boards aren't wobbly after installation. Lay a minimum 500 gauge visqueen membrane above the insulation, taping any joints where overlapping. With liquid screeds make sure that the membrane is turned up along all walls and vertical objects. The floor is now ready for the underfloor heating pipework installation.

We recommend a minimum of 50 mm PIR insulation. If there isn't enough space for 50 mm insulation, 30 mm is recommended (and you can still fix the pipe using shorter 40mm clips). Always check that you apply to current building regulations.

If insulation is too thin, or none is fitted, you can lay down a A142 mesh then tie the pipe to the mesh using cable ties.

Care must be taken to protect the pipework whilst laying the screed. We recommend **65 mm – 75 mm screed to be laid over the pipes and the insulation**. Fibre screed or anhydrite screed can be 50 mm.

Always check with the floor finish manufacturer and fitters of any floor covering that it can be used for underfloor heating.

Timber suspended floors don't conduct heat as efficiently as screeded floors. This means that the heat output is less. Between the joists, install 50-70 mm PIR insulation boards with a tight fit. Use battens below to support the insulation.

The pipe is then clipped on the insulation with our clips. Then the flooring is laid on top of the joists. Be careful not to leave too much air space between the insulation boards and floor boards (25 mm is recommended). The joists need to be notched where needed for pipe runs.

For timber suspended ground floors (or buildings 20 years or older) we recommend:

To get the timber suspended floor to act as a screed floor giving out more heat, the air gap between the insulation and the flooring should be filled with a lightweight screed mix. This is also required if you are mixing a timber suspended floor and concrete floor - using the same manifold.

We recommend the infill for all properties that are not built to current building regulations. The mix consists of 10:1 sand/cement mix or 8:1 Lytag lightweight mix on top of the insulation, with enough water to hold the mix together. The additional load imposed on the floor by the mix is approximate 18 Kg/m². Note that the mix is not intended as load bearing, merely as a heat conductor. The thickness of the mix should be 25 mm (pipe included).

For upper floors grooved aluminium heat emission plates can be used as an alternative, if weight is an issue.

Watch our installation guide video here:

<https://www.youtube.com/watch?v=n5xemXIGvNY&t=46s&authuser=0>

Technical information on our website:

<https://www.underfloorheatingsystems.co.uk/technical-information/>

<https://www.underfloorheatingsystems.co.uk/underfloor-heating-design/>

<https://www.underfloorheatingsystems.co.uk/installation-service/>