

Single Circuit – Installation Manual

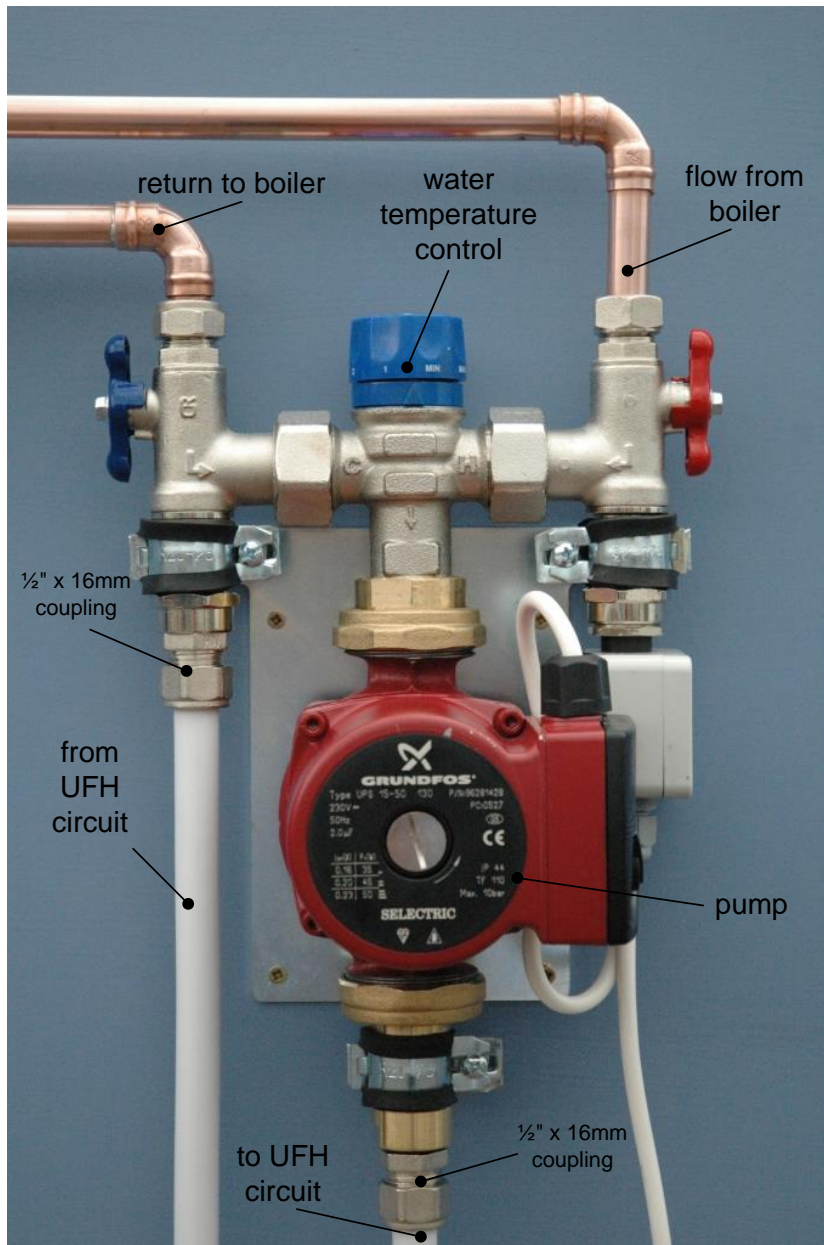

Unit 1, 79 Friar Street, Worcester, WR1 2NT

Tel: 01905 354 791

E-mail: info@underfloorheatingsystems.co.uk

Website: www.underfloorheatingsystems.co.uk

1. General Information

Read this entire document first!

- Pipe distance c/c 200 mm for boiler system or c/c 150 mm for heat pump systems. Pipe to be fitted 100 mm from walls. Always go with the flow to the cold spots first.
- Max loop length is 110 m. Try to use all the pipework supplied. The pipe is marked every metre so you know when it is time to go back to the control unit.
- The control unit should always be located near or within the room it is serving.
- The room thermostat controls the pump when boiler is on.
- Pipe is normally not laid under Kitchen and Utility units.
- To connect the pipe to the control unit, cut the pipe end squarely using the plastic pipe cutter. Re-round the pipe end with the calibration tool provided. Place the nut over the pipe, then the olive and finally push in the insert into the pipe and then attached to the control unit.
- If the pipe is kinked when bending, the pipe should be straightened and rearranged so that the location of the kink remains in a straight length.
- Prevent people from walking over the pipes, keep tools etc away from the pipes.
- Fill the system as instructions provided. **Do not fill from the boiler filling loop.**
- It is important to purge the pipework from the boiler to the control unit, to avoid air being introduced into the underfloor heating system.
- Hardwood timber flooring must be conditioned before fixing.
- Screed or chipboard flooring should be laid immediately after the pipe laying to protect the pipe.
- When using a liquid screed a minimum 500 gauge membrane must be fitted above PIR, also expansion edging strip fitted around all walls and vertical objects such as pipes.

Maximum heat output for underfloor heating systems are 100 W/m² for concrete floors and 70 W/m² for timber suspended floors. For any underfloor heating system to work efficiently the property needs to be built to current building regulations. Carpet and underlay should not exceed 2.5 Tog.

If you are using the single room pack for a Conservatory, note that it will extend the time you can use the Conservatory for, not to keep it at 20 degree C all year as the heat losses are higher than 100 W/sqm in a Conservatory. Usually, this is also the case with radiators.

We recommend a **minimum of 50 mm of PIR floor insulation** for the underfloor heating system. This is very high quality insulation and can be used for both concrete and timber suspended floor constructions.

The quote is based on clipping the pipe to the insulation board. Minimum screed thickness 65 mm of screed – 50 mm fibre screed or 50 mm liquid screed.

The screed must be allowed to dry for a minimum of 6 to 8 weeks before the heating is operated. As the system is used for the first time, the mixing valve must be set to minimum setting to let the moisture in the screed to dry out. The temperature should be increased by two degrees every day until the mixing valve is set at 45°C. Floorboards must have moisture content lower than 7 % before they are installed. We do not recommend floorboards thicker than 25 mm, see website link under technical for more information about floorboards. Always check with the manufacturers of any floor finish that it will work with underfloor heating.

For stone and ceramics tiles it is recommended that flexible adhesives and grout are used. Avoid underlays for carpet with felt and rubber crumb type. With Vinyl check the vinyl floor manufacturer that it works with underfloor heating – floor sensors can be fitted for sensitive floors. Laminate flooring should have an expansion gap for movement.

2. Design

Below are guidelines on how to design your UFH installation.

Before you commence your installation take time to design your pipe layout to use the maximum amount of pipe but be careful to make an allowance for the location of the control unit. Set the pipework in 100mm from all walls/edges.

As the temperature of the UFH system is controlled by the blending valve in the Control Unit, reducing the pipe centres does not increase the room temperature but does reduce the heat up time.

Use the chart below along with the area of your room to determine the optimum pipe spacing. The spacing is described as *c/c*; this is the distance between the centreline of the pipes.

Room Size	Coil	c/c	Blending Valve Temperature
20 m ²	100 m	200 mm	45
15 m ²	100 m	150 mm	40

If the room is smaller than 15m² it is still recommended to use as much pipe as possible. But, normally *c/c* 150mm is the minimum spacing.

We recommend setting the water temperature at 45°C for screeded floors, which can be increased to 50°C if larger pipe centres are used to achieve a maximum floor temperature of 29°C.

If a timber floor finish or floating floor is proposed set the blending valve to achieve a maximum floor temperature of 27°C to avoid shrinkage of the timber boards.

3. Installation

The Compact UFH System is pre-assembled to allow speedy and simple installation for extensions and conservatories. The control unit comes complete with wall fixing kit and the pump is pre-wired in conjunction with a flow temperature thermostat. There is also a mains connection point and removable link for connection of a room stat (supplied) if desired.

The control unit has integral ball valves for connecting/isolating the primary heating system, an adjustable thermostatic blending valve and Grundfos 7 metre A rated circulating pump all secured to a fixing bracket with anti-vibration mountings for silent operation. 1/2" female tapings are provided with compression adaptors for connecting the UFH pipework.

Before beginning the installation check that there are no missing items. Refer to the pack contents list below. List of items included in the Compact UFH System:

- 100 m 16x2 Multilayer pipe
- 300 no. pipe clips
- 2 no. 16x2 pipe adapters
- Tools – 1 no. Pipe Cutter and 1 no. Calibration Tool
- 1 no. 240v Room Thermostat
- Pre-assembled control unit

4. Installation – Preparation

Make sure that the floor is level and clean and the room is empty. Next install your floor insulation (not supplied). We recommend a minimum of 50 mm high-density PIR insulation such as Recticel, Xtratherm, Celotex, Kingspan etc. High density insulation's have better insulation properties and allow the use of pipe clips.

PIR insulation board manufacturers recommend that you tape the joints to prevent screed ingress, which can form cold bridges. Also lay a visqueen membrane above insulation and perimeter edge insulation OR expansion edging strip around all walls and vertical objects.

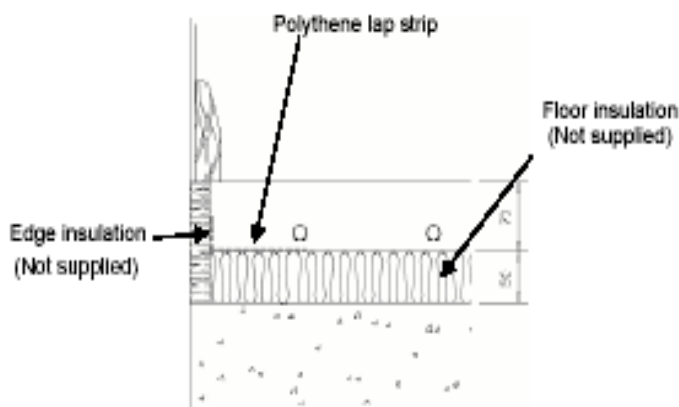

Diagram 1

5. Installation – Installing the Control Unit

The Compact UFH System is designed for wall fixing and ideally should be mounted in a horizontal position with the electrical connection box uppermost. However, it can also be mounted vertical to pump up or down if desired. Provision should be made to vent air to protect pump from cavitation.

The unit must not be floor mounted or in any position that inclines the pump shaft vertical. Refer to the pump installation leaflet enclosed.



Choose the location for the unit ensuring adequate clearance and accessibility for pipework and any subsequent maintenance. This is particularly important if enclosed within a cupboard space for example.

Locate the unit on the wall and mark the hole fixing positions through the bracket.

Take care to protect any electrical equipment and cables during handling.

When connecting the pipe to the manifold use the cutter supplied to cut the pipe square then calibrate the cut end to round the pipe ready to accept the compression adaptor. As the adaptor has integral 'O' rings it is not essential to use further sealant such as PTFE tape.

6. Installation – Pressure Testing & Screeding

Before screeding and before connecting the unit to the primary circuit it is recommended to pressure test the system. Connect a mains pressure hose to the red ball valve and a hose or bucket to the blue ball valve on the control unit. Open both valves fully & fill the system to purge all traces of air from the system.

After all the air has been removed it is recommended to pressure test the system with 6 bar pressure for 24 hours. We recommend maintaining the system under pressure whilst screeding.

Note, if there is a risk for the air temperature dropping below freezing, then you must protect the pipes and control unit from freezing. It is always recommended to lay screed on top of the pipes as soon as they have been pressure tested.

Use minimum 65 mm of sand and cement screed – or minimum 50 mm fibre screed or 50 mm liquid screed. Note that the screed drying time can be up to 6 - 10 weeks before the underfloor heating system is operated.

The mixing valve needs to be set at minimum temperature when commissioning the system. Rapid heating of the screed can cause it cracking – hence increase the temperature by only 1 degree C per day until reaching the desired setting.

7. Installation - Electrical

TYPICAL ELECTRICAL CONNECTION SINGLE CIRCUIT UFH + EXISTING S PLAN SYSTEM + SYSTEM BOILER

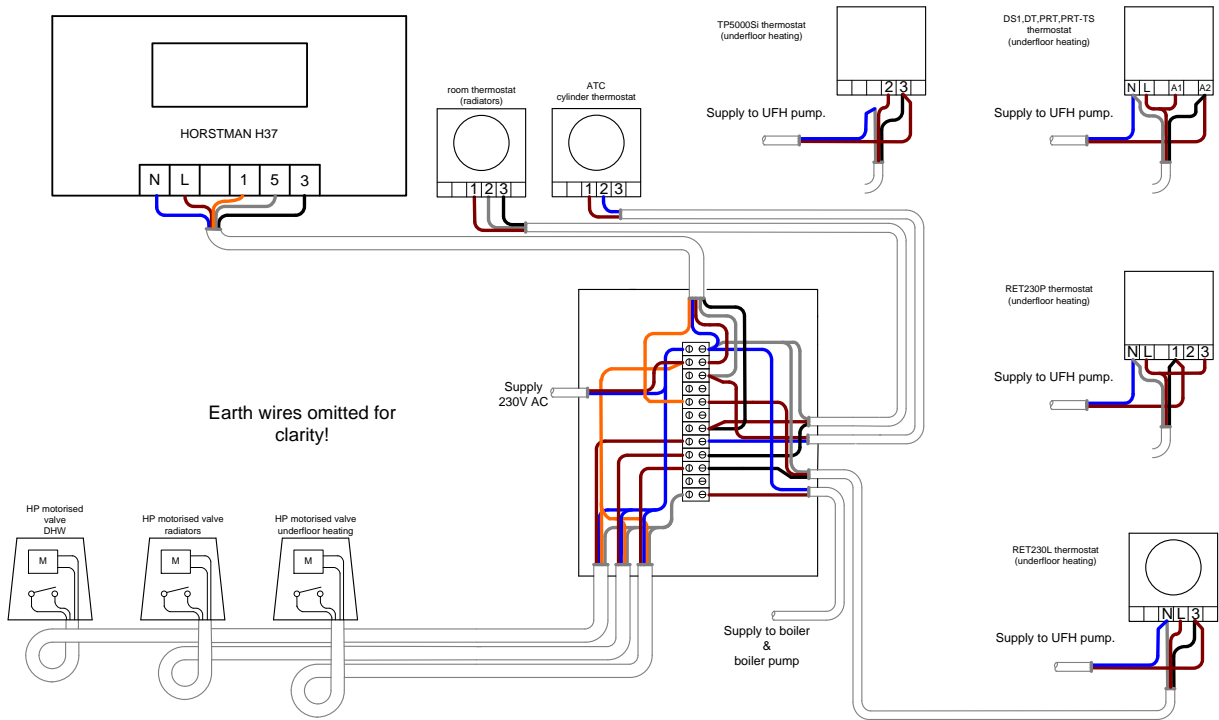

TYPICAL ELECTRICAL CONNECTION SINGLE CIRCUIT UFH + RADIATORS + COMBINATION BOILER

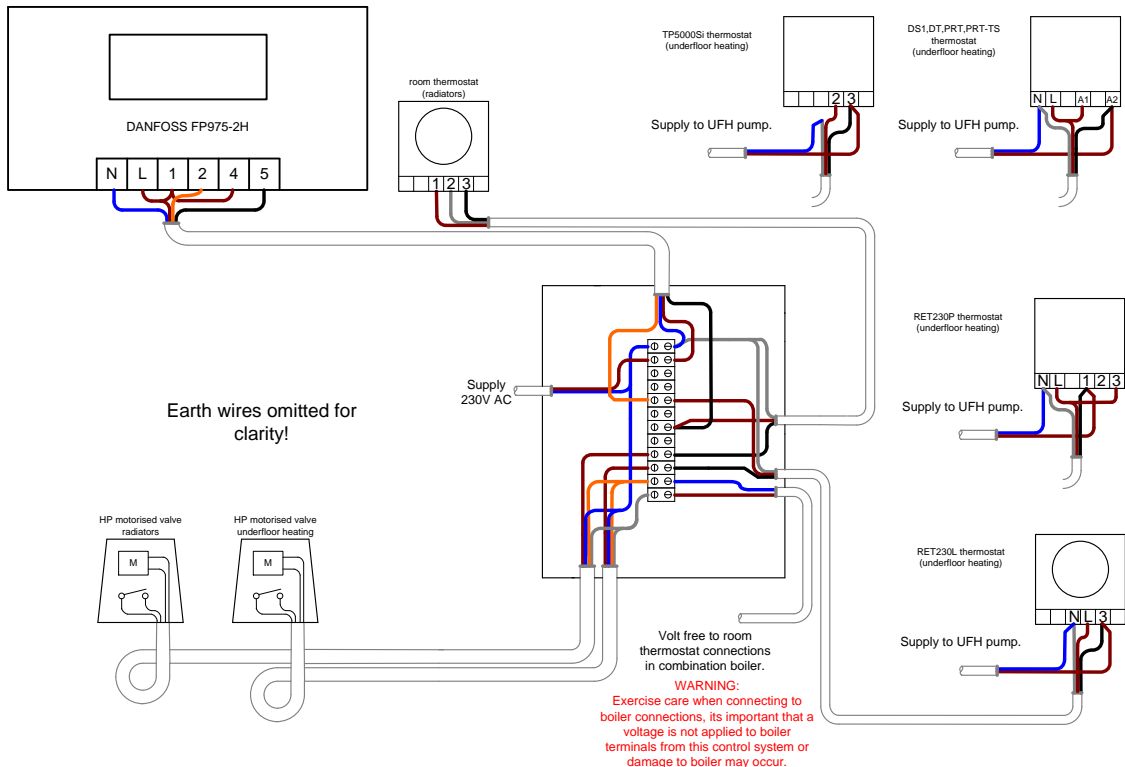

8. Installation - System schematics.

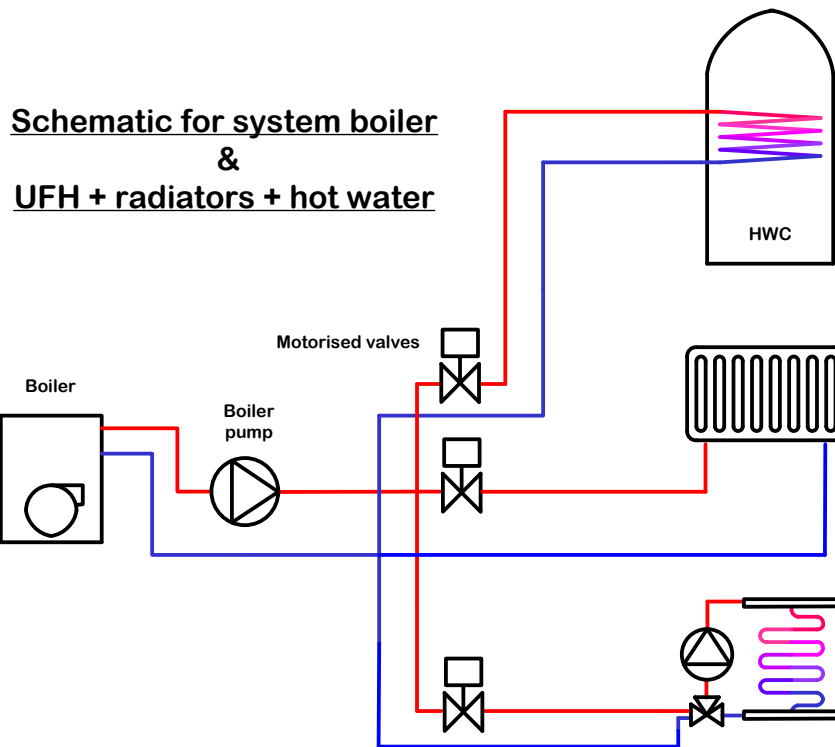

**Schematic for gas combination boiler
&
underfloor heating + radiators**

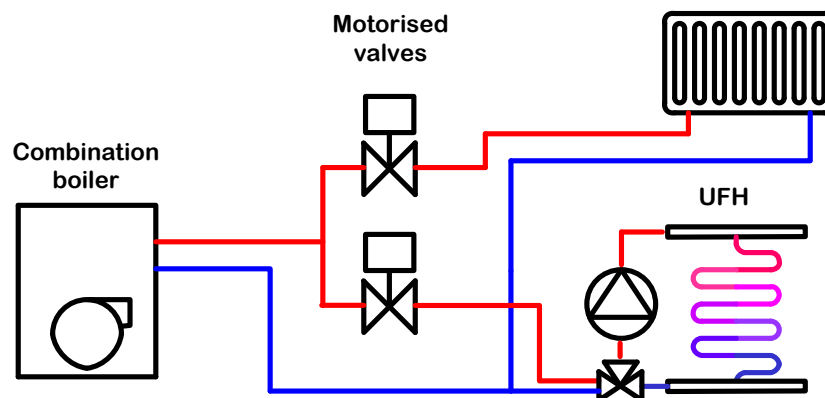

9. Installation - Operating Principles

When the primary heating circuit is on and the heating water temperature has reached approximately 43°C and the room thermostat is calling for heat, the pump will activate and feed the under floor heating loops.

The blending valve will maintain the temperature of the heating loop by continually blending the flow from the boiler with the cooler return flow from the underfloor heating loop. The heat output can be adjusted with the control knob on the blending valve to suit different floor structure and comfort levels.

The room thermostat will switch the pump off when the selected room temperature is reached. When the primary heating is off and the room stat is calling for heat, the pump will continue to run until the heating loop temperature falls to approximately 30°C. when it will automatically switch off.

10. Installation – Settings

The thermostatic blending valve has a temperature setting range between 35°C and 60°C as shown below:

Min = 35°C 1 = 40°C 2 = 44°C 3 = 48°C 4 = 50°C 5 = 54°C 6 = 58°C
Max = 60°C

Initial setting of the thermostatic blending valve (after the heat up/screed drying period) should provide the following temperatures at the flow pipe control unit. Screeded floors 40-48°C Timber floors 55-60°C

These initial settings can then be adjusted to provide comfort. A maximum floor surface temperature of 29°C should not be exceeded (wet areas such as bathrooms, 35°C) as this will lead to feelings of discomfort. With timber floor finishes including strip laminate products the maximum floor temperature of 27°C should not be exceeded as this may result in excessive material shrinkage.

11. Commissioning

- 1) Floor screeds must be cured before any heat is applied, a general rule of thumb is to allow 1 day per 2 millimetres of screed.
- 2) Timber floor with drymix infill can have heat applied immediately, the drymix must be dried completely before laying the flooring.
- 3) Hardwood timber flooring must be 'conditioned' before fixing.
- 4) It is important to purge the pipework from the boiler to the control unit, to avoid air being introduced into the underfloor heating system.
- 5) Initially start the system with the thermostatic valve set at min (35°C).
- 6) Increase the setting by 1° per day, up to a maximum of 48° for concrete floors, max 60° for timber floors.
- 7) NOTE. When first starting up the system it may take 12-24 hours for the heating effect to become apparent!

12. (Most Popular) Floor Types

Timber Suspended Floor Between Joists

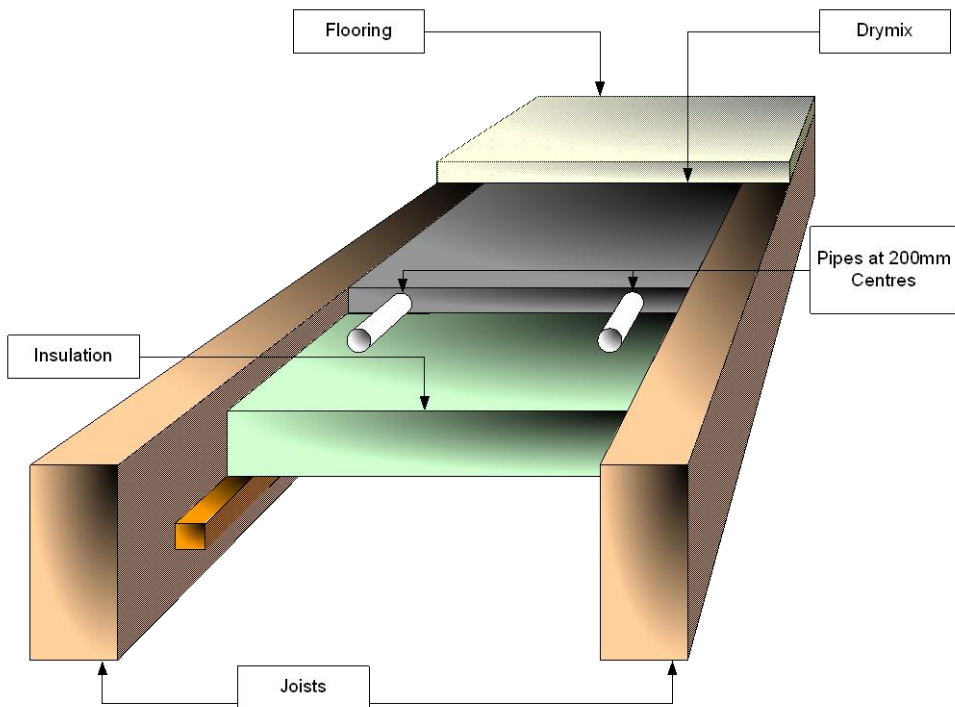

The Drymix is needed for Ground Floor, older buildings and if concrete floor and timber suspended floor are on the same floor. For First Floor applications when property is built to current building regulations an air gap is fine, still good to use the drymix as will give out more heat.

Concrete Floor with Staples

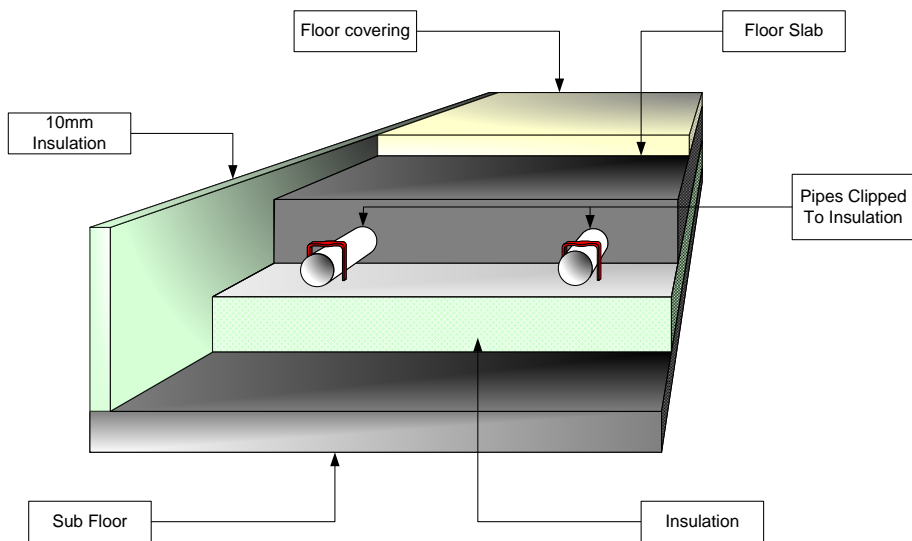

The Underfloor Heating system can be fitted in both concrete and timber suspended floors. See picture above. For other floor constructions please contact us and we will explain installation procedure, for example you can also do a floating floor